



Installation Instructions

ELEKTROMAT

FS 25.20-30,00

Model: 10005392 00002

-en-

Status: 24.08.2022

Table of contents

1	Safety-relevant chapter	3
	Explanation of symbols.....	3
	Specified use	3
	General safety instructions	4
2	Technical data	5
3	Product overview	6
4	Storing	7
5	Transport	7
6	Mechanical installation	8
	General safety information	8
	Permissible mounting positions	8
	Mounting	9
	Connection elements	10
	Work steps.....	11
7	Electrical installation	13
	General information	13
	Attaching the connection cables.....	14
	Mechanical limit switch - function	15
	Mechanical limit switch - setting the final limit position.....	15
8	Motor connection	18
9	Limit switch connection	18
10	Universal brake	19
11	Maintenance	21
	Maintenance checklist	21
	Checklist for fault correction	22
12	Disposal	23
13	Declaration of Incorporation / Declaration of Conformity	24

Schematic representations are based on product examples. Deviations from delivered products are possible.

1 Safety-relevant chapter

Explanation of symbols

The following symbols are used in these installation instructions:

⚠ DANGER

Safety note: Non-compliance will result in death or severe injury.

⚠ WARNING

Safety note: Non-compliance can result in death or severe injury.

⚠ CAUTION

Safety note: Non-compliance can result in injury.

NOTICE

Note: Non-compliance can result in material damage and impairment of product functionality.

i NOTE

Note: Points out useful additional information.

Specified use

The drive unit is intended for vertically moving doors for the protection against fire and smoke. The doors close by gravity in the case of a fire.

The drive unit must be protected against moisture and aggressive environmental conditions (such as corrosive substances). The drive units are only suitable for indoor use. Appropriate protective measures must be taken for outdoor installation. The drive unit is not intended for hazardous areas. The values specified in the technical data of the drive unit must not be exceeded. The safe operation can only be ensured if used as specified.

Target audience of the installation instructions

These installation instructions are intended for competent personnel trained in handling doors. Competent personnel qualify by specialist knowledge, skills and practical experience. Such personnel can safely carry out installation, maintenance and modernisation as instructed.

Safe operation

The safe operation of the product can only be ensured if it is used as specified. Follow the installation instructions. Observe all specifications, especially warnings, when installing the product in the overall system. GfA is not liable for damage resulting from non-observance of the installation instructions. The resulting overall system must be reassessed for its safety in accordance with applicable standards and directives (e.g. CE marking). These installation instructions refer only to a part of the overall system and are not sufficient as the sole instructions for the overall system. The installer of the system must prepare the instructions for the overall system. We recommend entering the danger area of the system only when the drive unit is at a standstill.

General safety instructions

⚠ WARNING

Failure to follow these installation instructions may result in severe injury or death.

- Please read these instructions before using the product.
- Keep these instructions handy.
- Include these instructions when passing on the product to third parties.

⚠ WARNING

Danger from improper use of the product!

- Do not let children operate the product unsupervised or use as a toy.

⚠ WARNING

Danger to life from incorrect installation!

Work carried out improperly may result in death or severe injury from electrical current or falling parts

- Allow only competent people to carry out the work.
- Disconnect all cables from the power supply.
- Observe valid regulations and standards.
- Use suitable tools.

⚠ WARNING

Danger to life from falling objects if the drive unit is subjected to impermissible forces!

Inadmissible forces (examples: collision with a forklift, dropping the drive unit, tearing or pulling on the motor) lead to damage to the drive unit. There is a risk of severe injury or death from falling objects.

- Prevent impermissible forces from acting on the drive unit,
- Check the drive unit for damage if impermissible forces have acted on it. Look even for minor damage. Lock the door during the inspection.
- Contact the service department if you have difficulty assessing the damage.

GfA ELEKTROMATEN GmbH & Co. KG
Wiesenstraße 81
D-40549 Düsseldorf

🌐 www.gfa-elektromaten.de

✉ info@gfa-elektromaten.de

2 Technical data

Designation		Unit
Output speed	20	rpm
Output torque	250 (250) ¹⁾	Nm
Output / hollow shaft	30,00	mm
Series	SRG-FS25	-
Limit switch range (maximum revolutions of the output / hollow shaft)	20	-
Supply voltage	3N~ 400	V
Operating current	2,00	A
Operating frequency	50	Hz
Power factor cos φ	0,68	-
Safety circuit	24	V
Degree of protection	IP 54	-
Temperature range	-10 / +40 (+60) ²⁾	°C
Operating sound pressure level	< 70	dB(A)
Cycles per hour	12 (8,3) ¹⁾	h ⁻¹
Max. holding torque	250	Nm
Max. load	-	N
Braking torque	13	Nm
Braking voltage	24	V DC
Rectifier type	-	-

Designation	Series			
	FS 15	FS 25	FS 50	FS 110
Braking power	16 W	24 W	26 W	26 W
Permissible radial load	3900 N	4350 N	9100 N	17000 N
restoring torque ELEKTROMATEN	15 Nm	15 Nm	22 Nm	30 Nm
Weight	26.5 kg	46 kg	66 kg	105 kg
Recommendation of number of teeth for sprocket and pitch	15 3/4"	15 3/4"	15 1"	15 1 1/4"

1) Specification in () according to EN 60335-2-103.

2) When using a temperature range of +40°...+60°C use half of maximum cycles per hour.

Output speed

The centrifugal brake limits the output speed in the case of a fire when the power supply fails. In this case, the output speed is higher than the one in mains operation.

Maximum holding torque

Denotes the maximum torque that may act on the drive shaft of the drive unit when the door is stationary.

Operating current

In door drive units, the operating current can be up to 4 times the rated current for a short time.

Cycles per hour

The specified cycles per hour apply to an even distribution of the cycles per hour that must not be exceeded.

3 Product overview

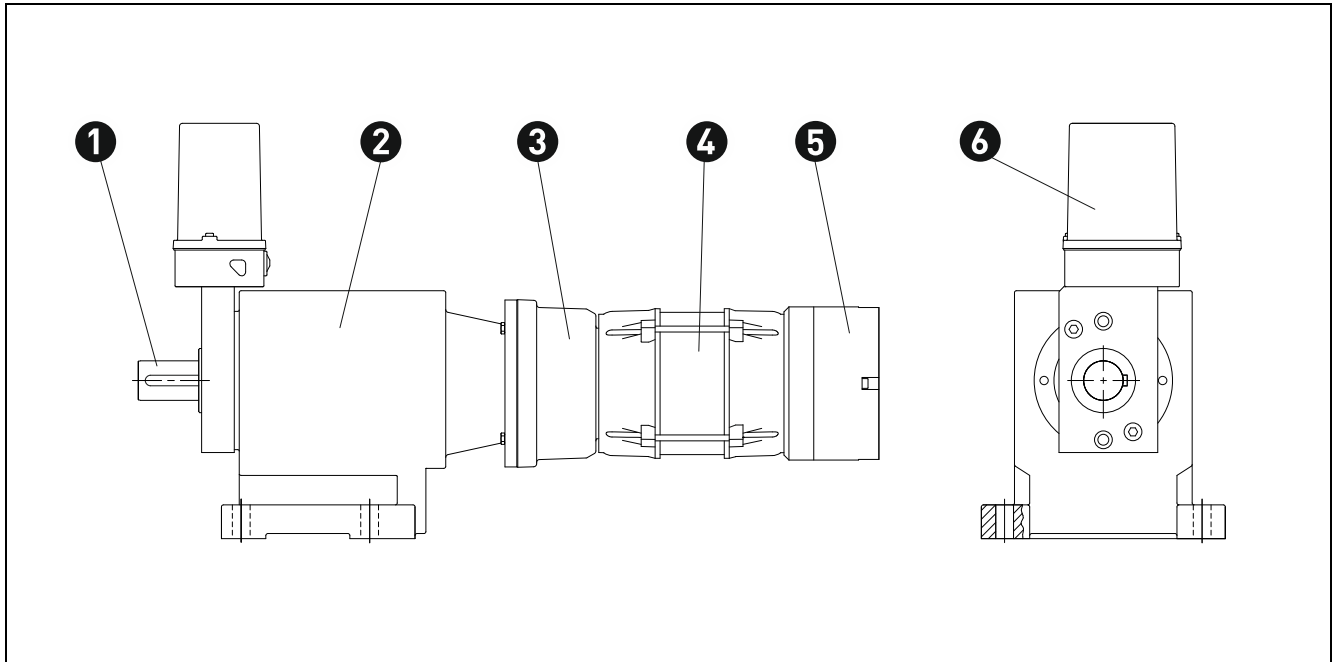

No.	Designation
1	Output shaft: Note the recommendation for the number of teeth on the sprocket and the pitch in the technical data.
2	Spur gear
3	Intermediate flange with centrifugal brake: In the case of fire, the centrifugal brake regulates the speed that the door uses to close. In the case of fire, the door closes 10% to 15% faster than with electrical operation.
4	Motor: three-phase motor with thermal protection switch.
5	Universal brake: Combination of working current brake and spring-applied brake (see chapter Universal brake).
6	Limit switch cover

1) Specification in () according to EN 60335-2-103.

CAUTION

Component damage can result!

The maximum current that can be switched over the limit switch is 1A for 230 V AC and 0.4 A for 24V DC.

4 Storing

Store the product in the original packaging.

Ensure the following environmental conditions for storage:

- Closed, dry, dark and vibration-free rooms
- Temperatures between +5 °C and +40 °C
- Relative humidity less than 70 %, non-condensing
- Dust protected
- Protected against corrosion (e.g. protection against saltwater)
- Protected against chemicals

5 Transport

Avoid bumps, impacts and vibrations during transport.

▲ CAUTION

Injuries, or damage to the drive unit!

Use aids for lifting and carrying if the weight of the drive unit exceeds 20 kg. Refer to the technical data for the weight.

Notice

Failure of electrical components during operation!

Do not lift the drive unit by the cables.

Lifting points

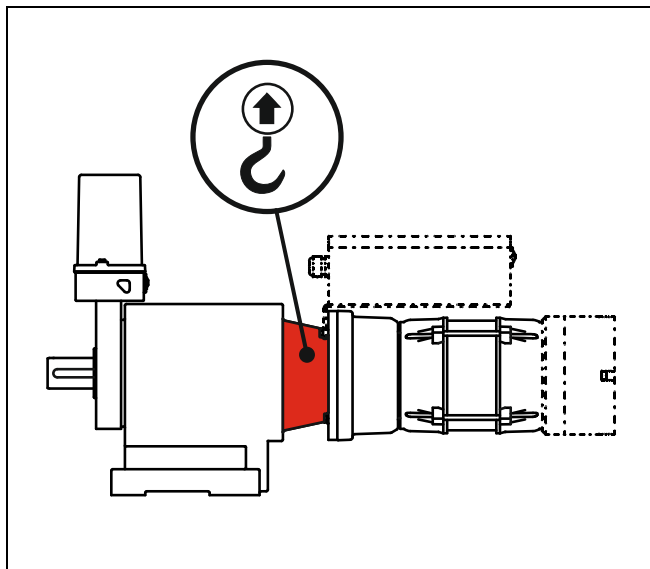

- Lift the product at the position shown.
- Use lifting equipment and load suspension devices with sufficient load-carrying capacity. Refer to the technical data for the weight of the drive unit.

6 Mechanical installation

General safety information

⚠ WARNING

Danger to life from electric shock!

Working on the mechanics may damage electrical lines or components. Danger to life or risk of severe injury from electric current.

- Disconnect all cables from the power supply.
- Secure the mains disconnecter against plugging in or switching on again.
- Allow only competent people to carry out the work.

⚠ WARNING

Danger to life from moving parts!

Moving parts may cause the risk of injury, for example through impact, shock, crushing, shearing or drawing in of body parts.

- Mount the product 2.5 m above the access level or use additional protective devices to prevent contact.

⚠ CAUTION

Injuries from hot surfaces!

The surfaces of the motor can get up to 100 °C during operation. This may cause burns.

- Mount the product 2.5 m above the access level or use additional protective devices to prevent contact.

Permissible mounting positions

Mount the drive unit in one of the mounting positions shown in grey. Incorrect mounting positions, for example, prevent emergency actuation or lead to premature wear due to insufficient lubrication. Other mounting positions are not permitted.

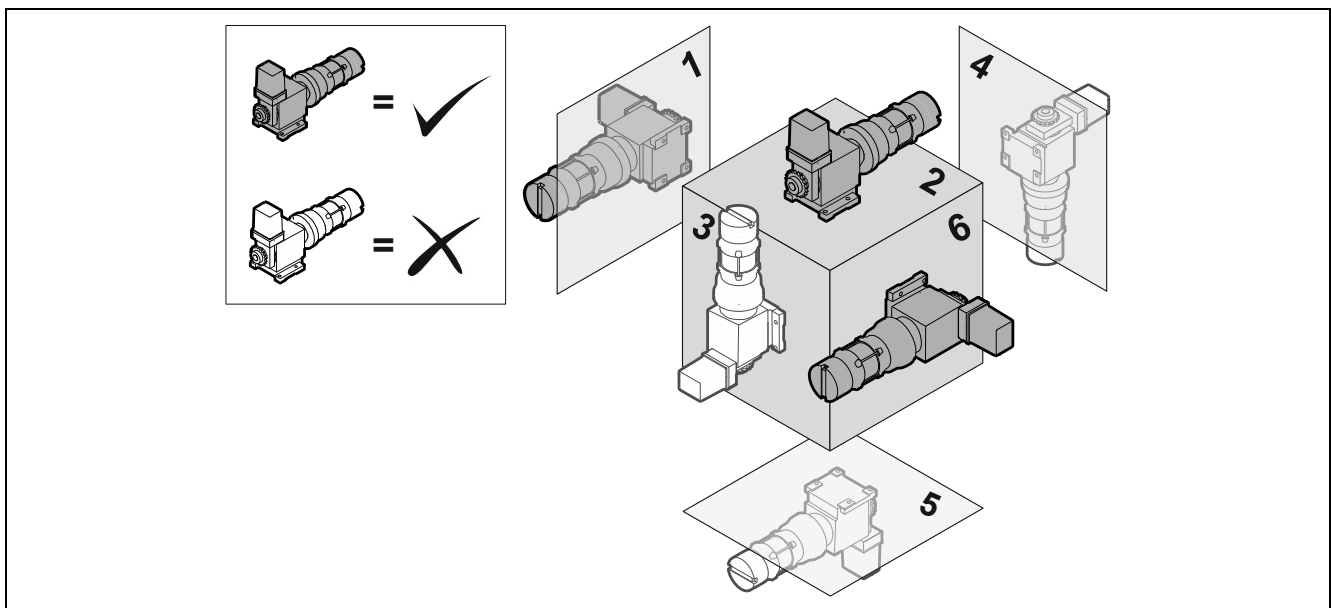

Mounting

Only use the fastening points shown for mounting the product. Alternative mounting options for separately available accessories are not described here. Use the mounting instructions of the accessories for this purpose.

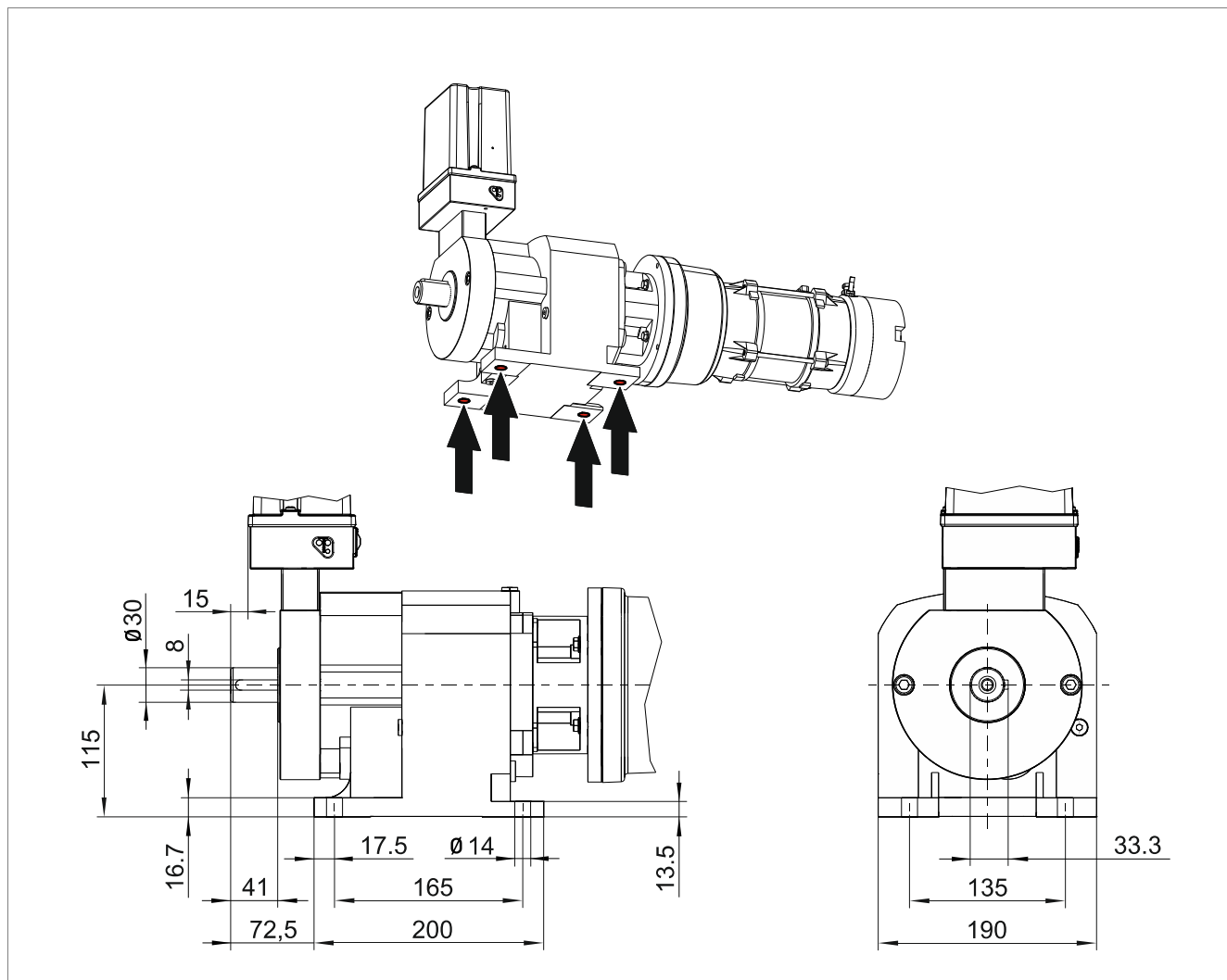

Connection elements

⚠ WARNING

Danger to life from falling parts and uncontrolled movements.

The permissible loads on structures, walls, fastenings, connection and transmission elements must not be exceeded, even with maximum holding or locking torques.

Please note the technical data of the drive unit.

- Note the following information on using connection elements.
- Also note the documentation of the door manufacturer.

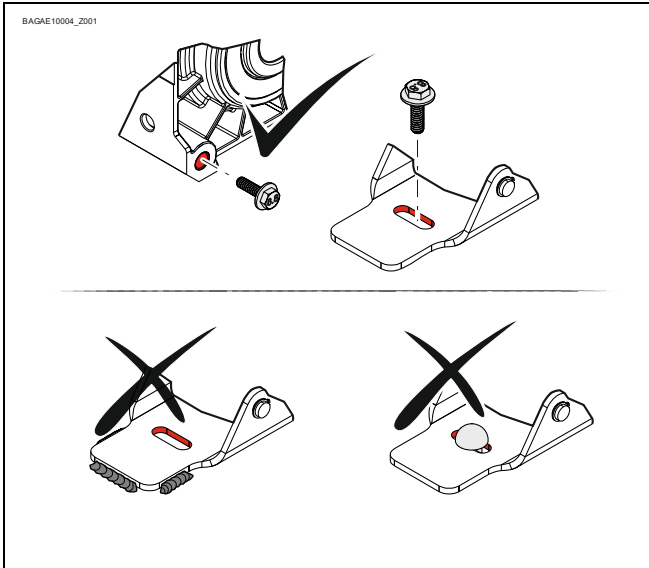

- Use only screw connections for mounting.
- Non-detachable connections (e.g. welded or riveted connections) are not permitted.

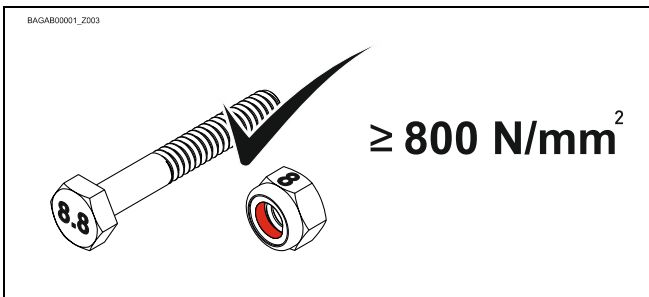

- Use connection elements with a minimum strength of 800 N/mm² (8.8).

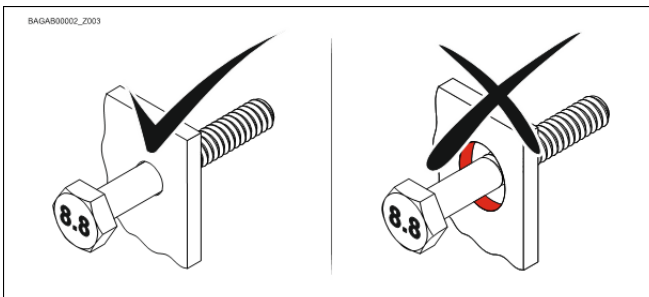

- Make maximum use of the existing hole diameters.

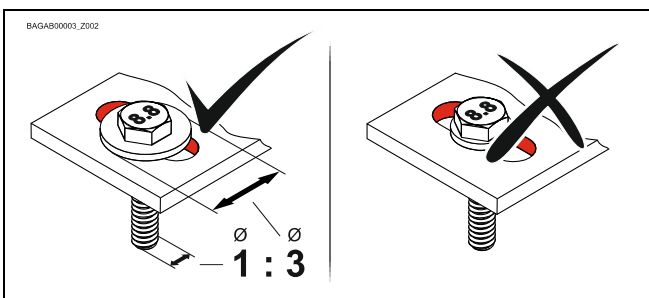

- Use adequately dimensioned washers for elongated holes.

Work steps

⚠ WARNING

Danger to life from incorrectly installed transmission elements

A chain with too little or too much tension may skip or break. As a result, parts of the door structure may become loose and drop. The drive unit or door construction may also suffer damage.

- Note the information given below on the selection and use of transmission elements.

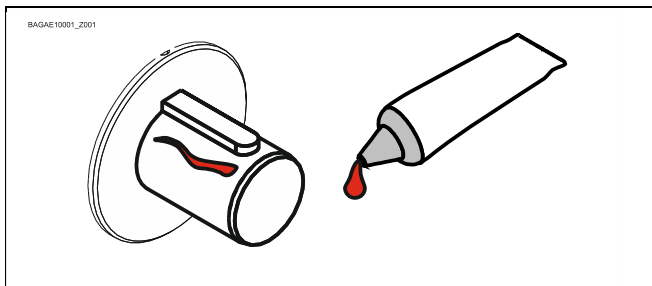

- Grease the output shaft and key thoroughly. Use suitable assembly grease.

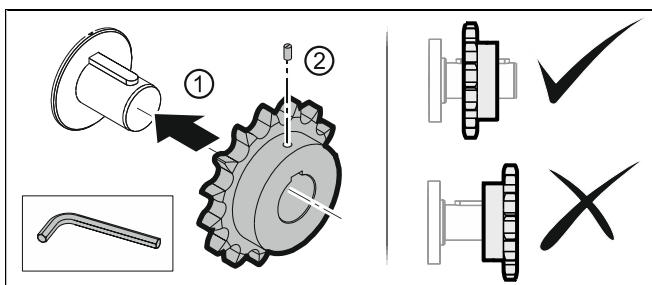

- Mount the sprocket (①). The hub side of the sprocket points away from the drive unit. The sprocket must lie fully over the key.
- Tighten the fastening screw slightly (②).

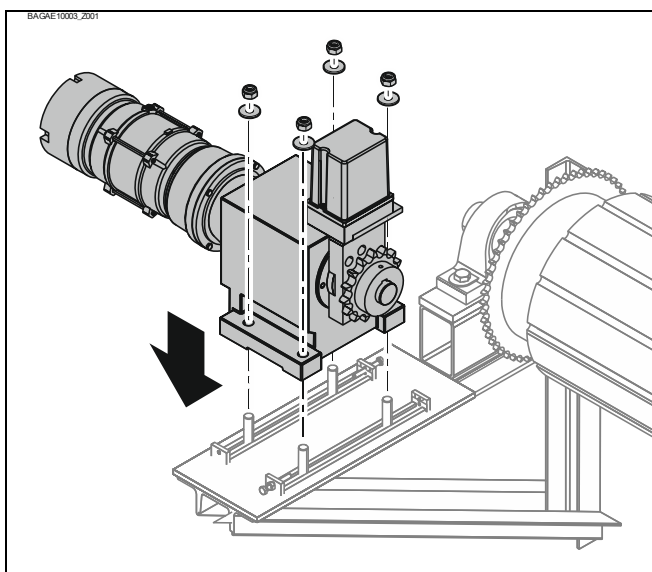

- Mount the drive unit.
- Tighten the fastening screws slightly.

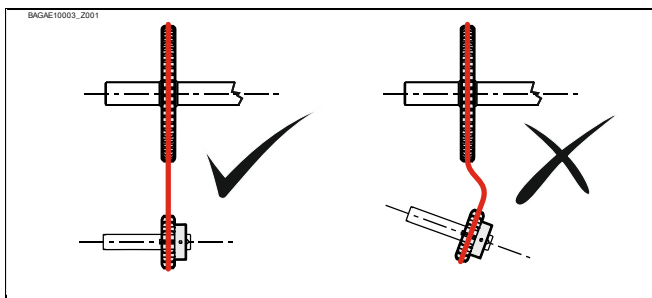

- Mount the chain.
- The sprockets of the drive unit and door must be flush.

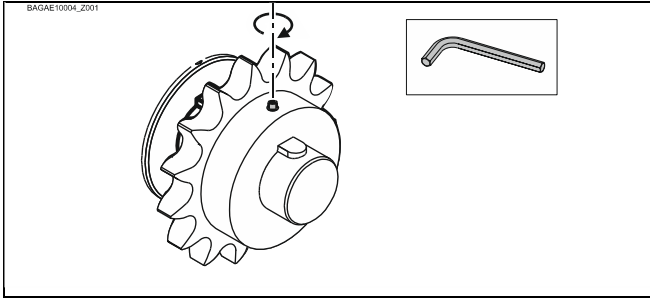

- Tighten the fastening screw of the sprocket.

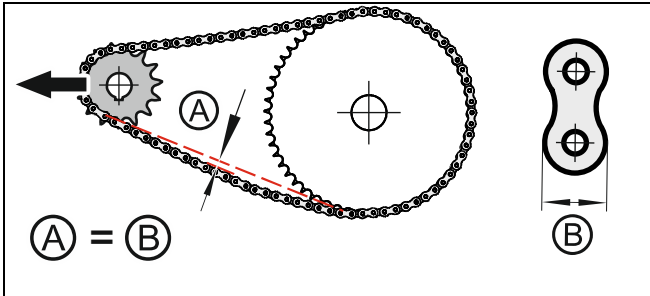

- Tension the chain. The slack side (A) must not exceed the height of a chain link (B).

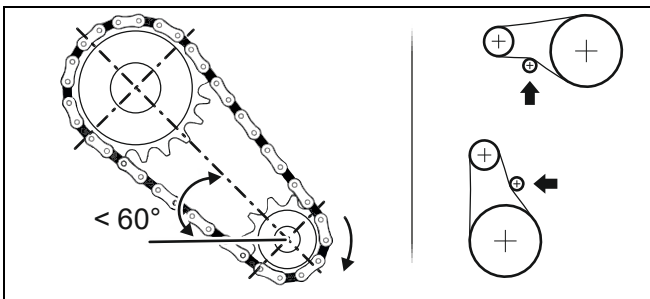

- We recommend using a chain tensioner.
- From an angle of 60° , a chain tensioner is required in the slack side.

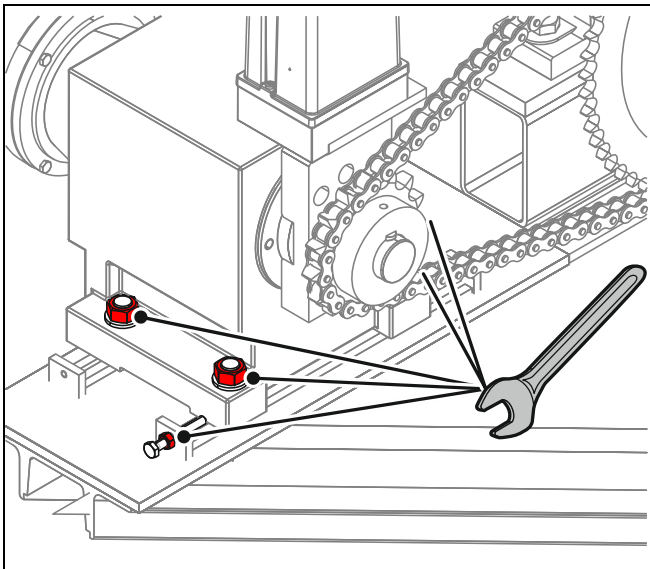

- Tighten all fastening screws. Also note the specifications of the door manufacturer.

7 Electrical installation

General information

⚠ WARNING

Danger to life from electric shock!

Improper wiring may result in severe or fatal injury from electrical current.

- Allow only competent people to carry out the work.
- Disconnect all cables from the power supply.

⚠ WARNING

Danger to life from uncontrolled movements!

Unauthorised switching on of the voltage during assembly and maintenance may lead to injuries as a result of uncontrolled movements.

- Secure the mains supply against being switched on or plugged in again.

⚠ WARNING

Danger to life from uncontrolled movements!

Failure of a phase in the motor supply line may lead to uncontrolled movements of the drive unit.

- Use fuse protection with an all-round switching circuit breaker with C characteristics.

⚠ WARNING

Danger to life from falling parts.

If the motor fails to switch off, the door could overrun the final limit positions. This may lead to a hazard from falling components.

- Use a door control that complies with the EN ISO 60335-1.

Attaching the connection cables

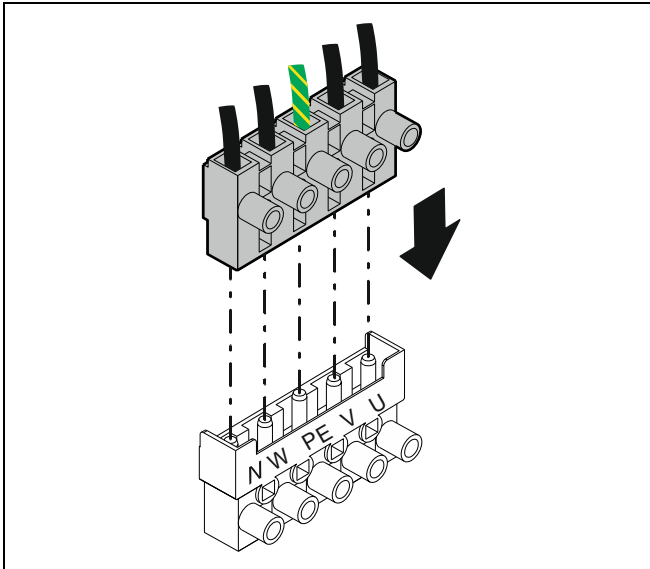

- Remove the limit switch cover.
- Plug in the motor connector.

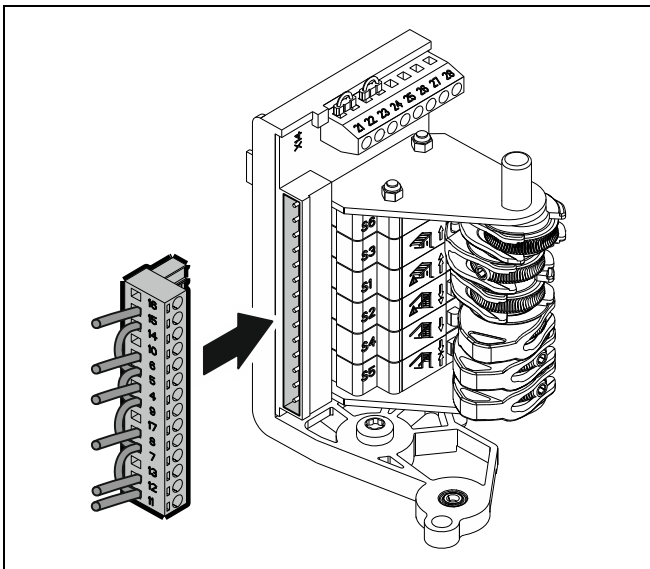

- Connect the limit switch plug.

Mechanical limit switch - function

Cams S1 - S6

Use cams S3 and S4 to specify the final limit positions OPEN and CLOSE of the door.

The cams S1/S3 and S2/S4 are mechanically linked. The emergency limit switches S1 and S2 only switch when the drive unit moves beyond the final limit positions OPEN and CLOSE. The emergency limit switches are automatically preset with the final limit positions. An actuated emergency limit switch interrupts the safety circuit. The drive unit switches off.

You can use the auxiliary limit switches S5 and S6 individually through terminals X12.11-13 and X12.14-16 (see the circuit diagram of cam limit switches).

Terminals 4 to 9: safety circuit

Terminals 4 and 9 form the safety circuit. If the safety circuit is interrupted, the drive unit switches off. Terminals 21 to 26 are factory-fitted with wire links. Instead of the wire links, you can connect additional safety devices (e.g. safety brake). Terminals 27 and 28 are used for the thermal protection of the motor.

Mechanical limit switch - setting the final limit position

The following explains how to set the limit switch and thereby specify the final limit positions OPEN and CLOSE.

Check the output rotating direction

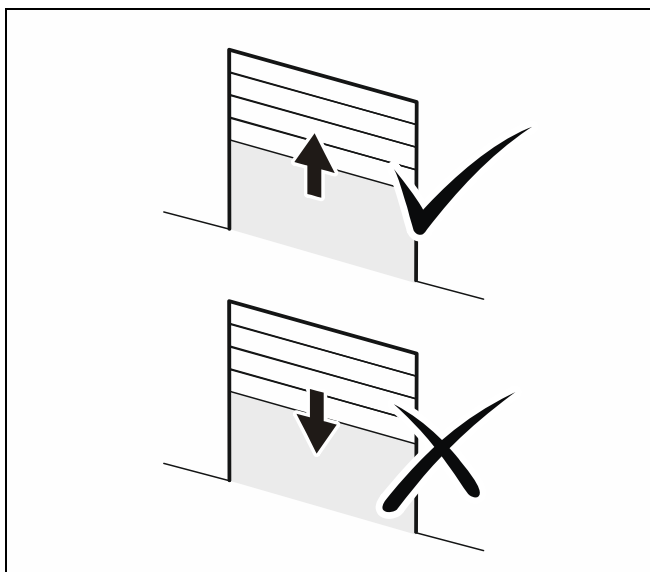

- Issue an OPEN command.
- If the door opens, the output rotating direction is correct. Continue with setting the final limit position OPEN.
- If the door closes, the output rotating direction is wrong. Change the output rotating direction before setting the final limit positions.

Setting the output rotating direction

If the movement direction of the drive unit does not correspond to the movement command, you can change the rotating direction. If you use a GfA door control, change the output rotating direction by using the programming. Follow the instructions for the door control. Otherwise change the output rotating direction as explained below.

⚠ WARNING

Danger to life from electric shock!

Improper wiring may result in severe or fatal injury from electrical current.

- Disconnect all cables from the power supply.

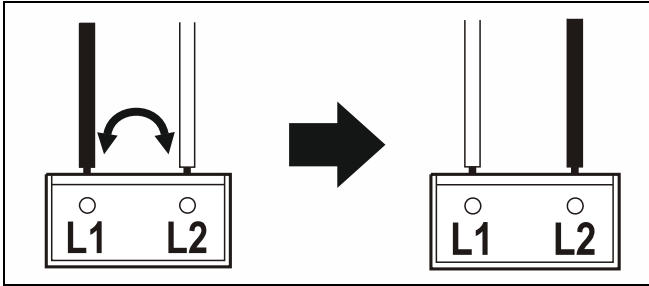

- Disconnect all cables from the power supply.
- Swap L1 and L2 in the supply line.
- Then switch the voltage back on.

Setting the final limit position OPEN

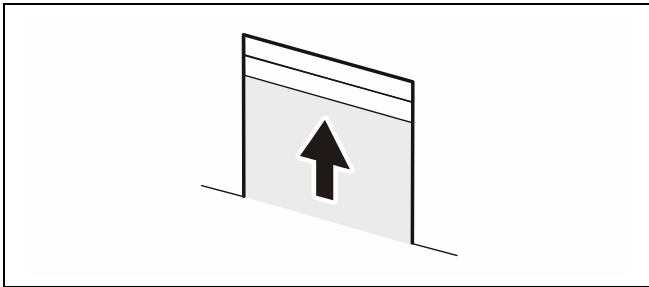

- Remove the limit switch cover of the drive unit.
- Issue an OPEN command until the door has reached the desired position.

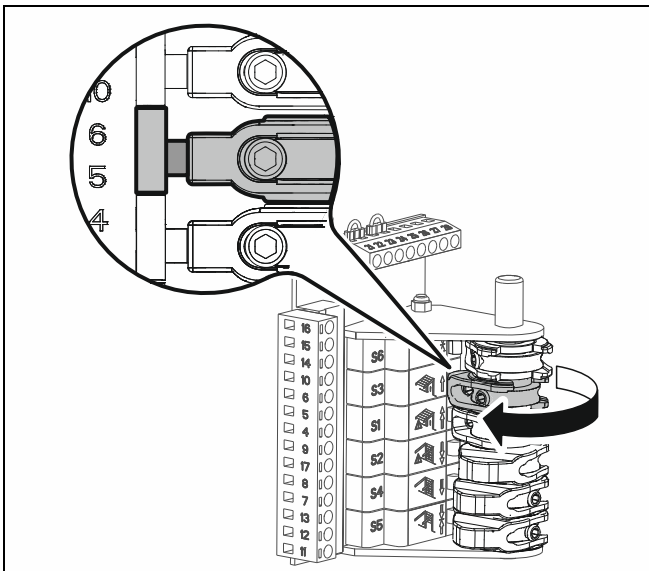

- Turn cam S3 to the centre of the switch.

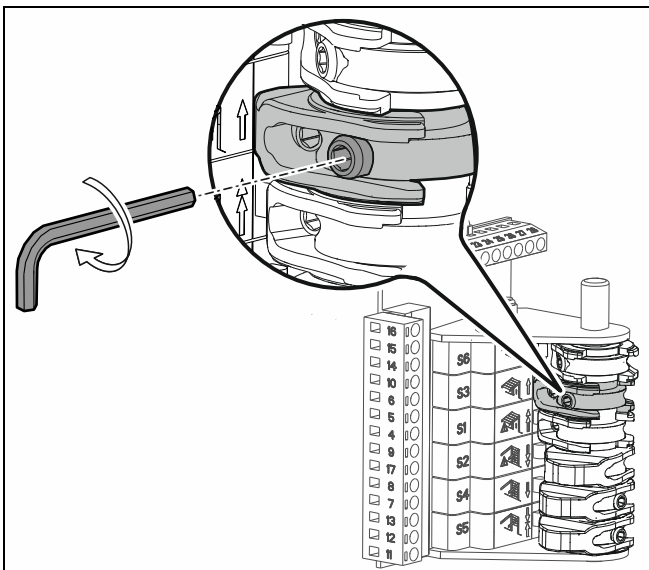

- Tighten the screw for coarse adjustment with the enclosed key.
- Check the set position by closing the door until the cam no longer touches the switch. Then move to final limit position OPEN.

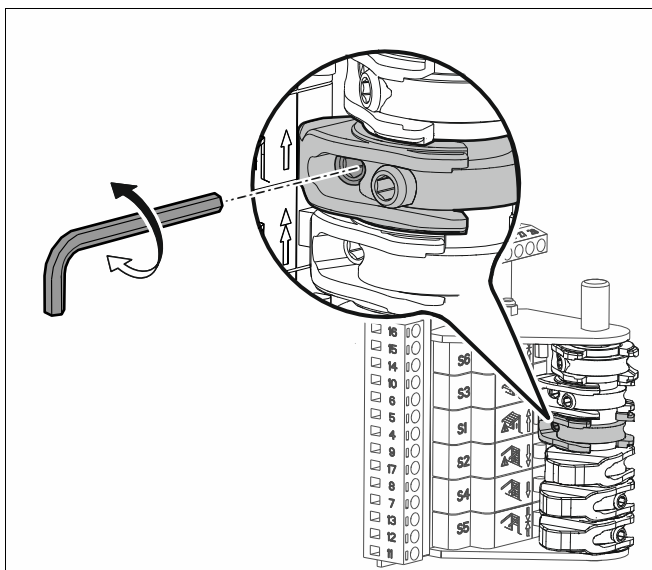

- The final limit position OPEN can be corrected by fine adjustment.
- Check the door position after a correction.

Checking and correcting the emergency limit switch OPEN

Setting S3 will automatically preset the emergency limit switch S1. Check whether the preset distance is sufficient.

▲ WARNING

Danger from falling objects!

If a limit switch does not switch, the drive unit is stopped by the emergency limit switch. If the emergency limit switch switches too late, the door can be damaged or parts of the door leaf may come loose.

- Set the emergency limit switch.
- A fixed stop of the door leaf may reduce the danger.

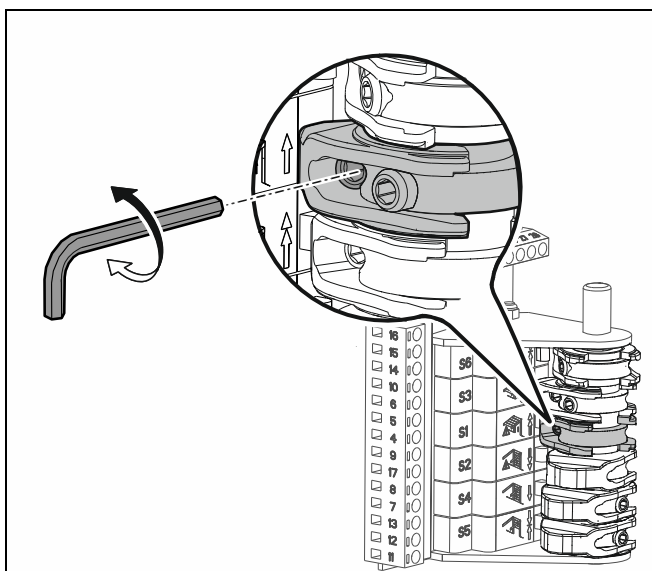

- Turn the screw for fine adjustment on cam S1 until the door stops without risk even when passing the final limit positions.

Setting the final limit position CLOSE and auxiliary limit switch

Proceed as for setting the final limit position OPEN.

8 Motor connection

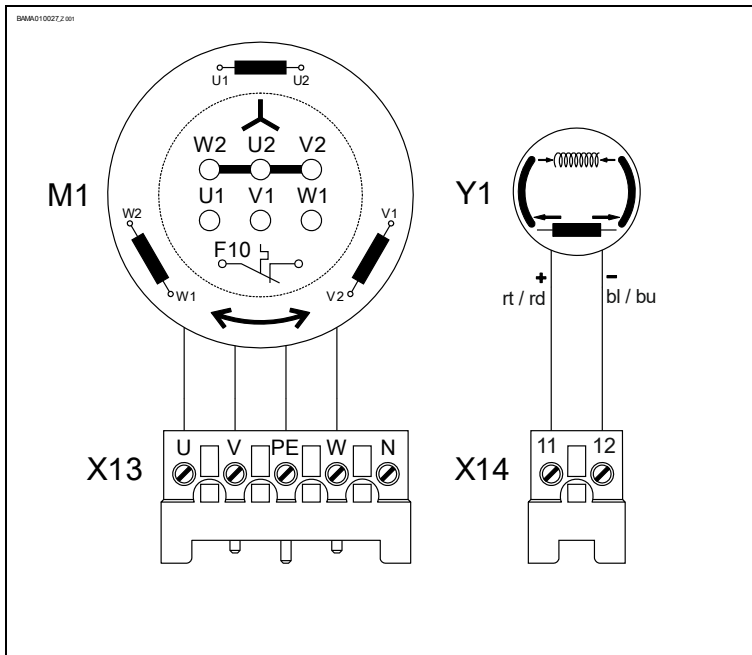

M1	Motor
X13	Motor plug
X14	Brake plug
Y1	Universal brake

9 Limit switch connection

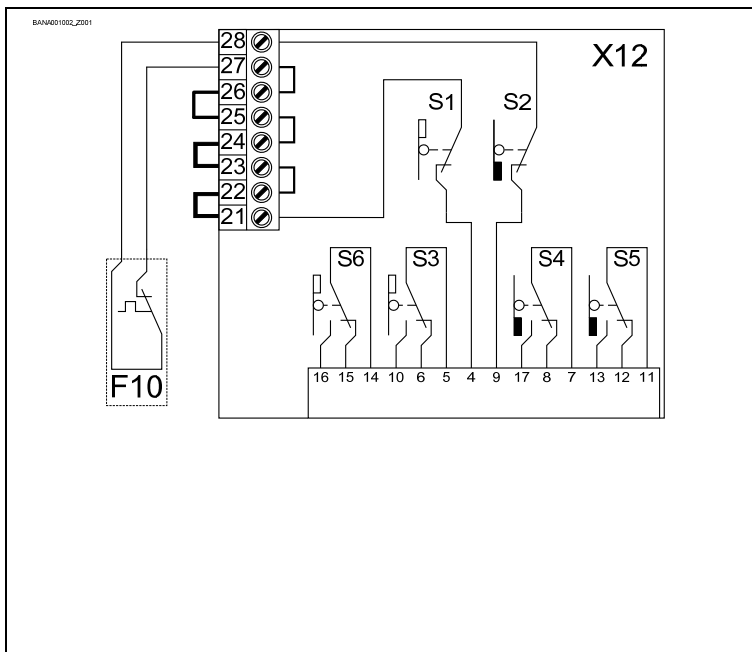

F10	Thermal contact
X12	Limit switch board
S1	Emergency OPEN limit switch
S2	Emergency CLOSE limit switch
S3	OPEN limit switch
S4	CLOSE limit switch
S5	Additional limit switch
S6	Additional limit switch

10 Universal brake

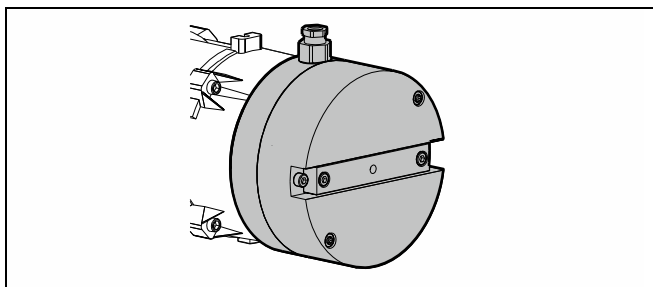

In the case of a fire, the universal brake opens and the door closes. For the duration of the assembly of the door, the universal brake can be switched to the assembly operating mode.

Connecting the power supply

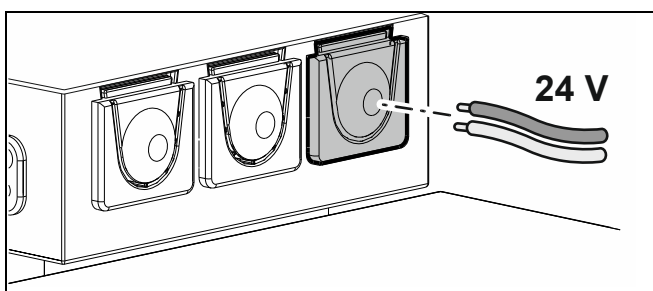

The universal brake must be supplied and controlled externally with a voltage of 24 V DC.

- Remove the limit switch cover
- Route the cables into the limit switch space. Use suitable cable glands.

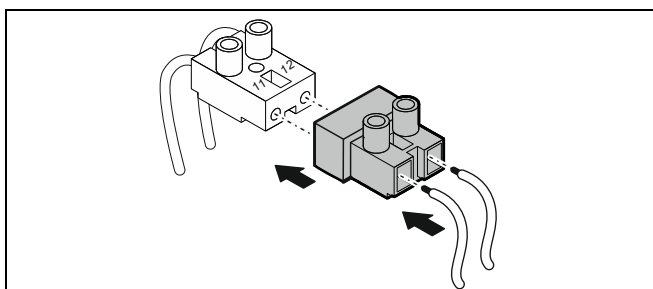

- Connect the power supply to terminals X13-11 and X13-12.
X13-11 = +
X13-12 = -

Setting the operating mode

- **Assembly mode:** For the assembly of the door. The braking force is applied when no current is present.
- **Fire-protection mode (factory-set):** For operating the door. When the power supply is interrupted, the door closes by gravity. The braking force is applied when current is present.

⚠ WARNING

Danger to life due to failure!

For the door to close in the case of a fire, the brake must be set to fire-protection mode.

Setting the assembly mode

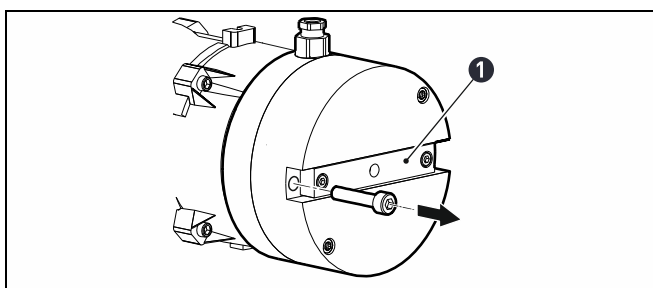

- Remove the screw from the hole on the side next to the guide rail (1).

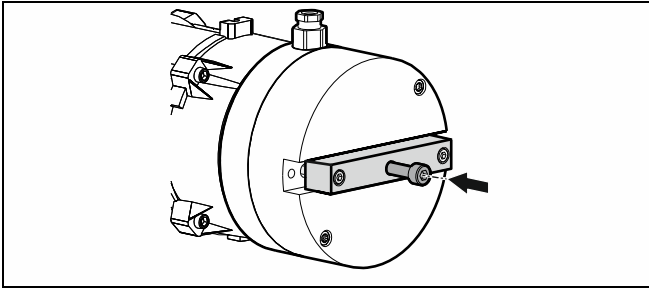

- Turn the screw into the centre hole of the guide rail as far as it will go. The guide rail lifts out of the groove.

The assembly mode has been set. The braking force is applied when no current is present.

Setting the fire-protection mode

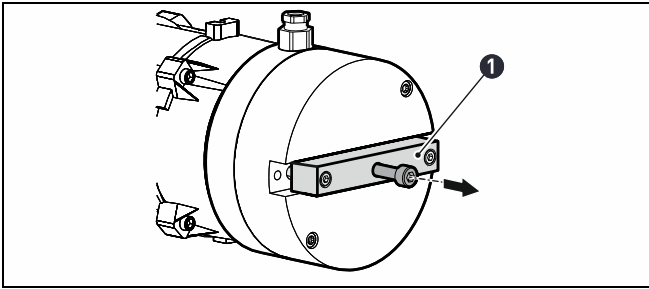

- Close the door.
- Remove the middle screw from the hole in the guide rail (1). The guide rail lowers into the groove.

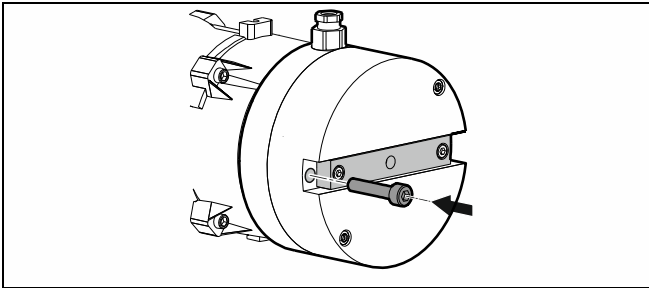

- Turn the screw into the hole on the side of the guide rail for storage.
- Apply 24 V to the brake.

The fire-protection mode has been set. The braking force is applied when current is present.

11 Maintenance

⚠ WARNING

Danger to life from electric shock

Improper wiring may result in severe or fatal injury from electrical current.

- Allow only competent people to carry out the work.
- Disconnect all cables from the power supply.
- Use original spare parts only.

⚠ WARNING

Danger to life from uncontrolled movements!

Unauthorised switching on of the voltage during assembly and maintenance may lead to injuries as a result of uncontrolled movements.

- Secure the mains disconnecter against being switched on or plugged in again.

Maintenance checklist

Check the following components of the ELEKTROMATEN at least once a year. Follow all applicable directives and standards as well as national regulations.

Component	Procedure
Mains supply, mains switch	<ul style="list-style-type: none"> ▪ Check the condition and function.
Cables	<ul style="list-style-type: none"> ▪ Check the cables on the ELEKTROMATEN for damage and replace damaged cables.
Mountings	<ul style="list-style-type: none"> ▪ Check screws for corrosion and tight fit. Tighten if necessary.
Limit switches	<ul style="list-style-type: none"> ▪ Move to final limit positions OPEN and CLOSE. The door must open or close fully. The emergency limit switch must not switch.
Brakes	<ul style="list-style-type: none"> ▪ Carry out a brake test. Note the overrun. The brake must be replaced after 50,000 switching operations.
Gearbox	<ul style="list-style-type: none"> ▪ The gearbox has lifetime lubrication. Check for oil leakage. A few drops are not critical. In the case of major oil loss, contact the service department. Do not open the gearbox. Do not add any oil.
Chain drive	<ul style="list-style-type: none"> ▪ Check sprocket and chain for wear.
	<ul style="list-style-type: none"> ▪ Check the chain alignment. Adjust if necessary.
	<ul style="list-style-type: none"> ▪ Check the chain tension: The slack in the slack strand should not exceed the height of a chain link. A tension that is too high will damage the gearbox. A tension that is too slack may result in the chain skipping or jumping off. ▪ Adjust the chain if necessary.

Cleaning

Use a cloth to remove dirt from the surface of the housing. Do not use water or detergents. Do not open the gearbox.

Checklist for fault correction

In the case of a fault, follow the instructions shown on the door control. Find damage to the door mechanism or door leaf first. The following only mentions faults on the drive unit.

When contacting GfA Service, have the serial number of the drive unit ready (see the 11-digit number next to "ID" on the nameplate).

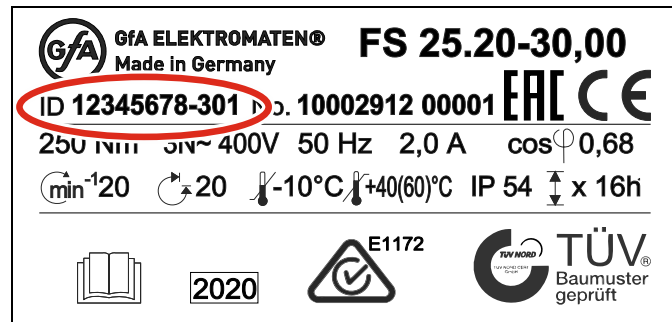

Fault	Potential cause	Corrective
The door does not fully close / open	The limit switch is set incorrectly.	<ul style="list-style-type: none"> Set the limit switch again. If the problem persists, contact service.
Oil leakage	Oil leakage at the gearbox	<ul style="list-style-type: none"> A few drops are not critical. In the case of major oil loss, contact service.
No drive movement	Damage to the motor winding	<ul style="list-style-type: none"> Noise test: Humming indicates that the winding is damaged. Contact service.
	Electrical damage to the motor	<ul style="list-style-type: none"> Electrical damage trips the fuses. Use a multimeter to find damage to the ELEKTROMATEN and contact service.
	Overheating of the motor	<ul style="list-style-type: none"> An overheated motor will be shut down. Allow to cool. Check the door mechanism for damage.

12 Disposal

Dispose of packaging

Dispose of the packaging material properly according to the local legal regulations or recycle it.

Dispose of old devices

Dispose of old devices properly according to local legal regulations. Return old devices to the return and collection systems available. You can also return GfA products free of charge. Please apply enough postage to the package and mark it as "old devices".

Notice

Environmental damage!

The gearbox contains oil.

- Ensure proper disposal according to local legal regulations.

Declaration of Incorporation

in terms of the Machinery Directive 2006/42/EC
for partly completed machinery Appendix II Part B



GfA ELEKTROMATEN GmbH & Co. KG
Wiesenstraße 81 · 40549 Düsseldorf
Germany

Declaration of Conformity

within the meaning of the EMV Directive 2014/30/EU
within the meaning of the RoHS Directive 2011/65/EU

We,
GfA ELEKTROMATEN GmbH & Co. KG
declare under our sole responsibility that the
following product complies with the above
directives and is only intended for installation in a
door.

Fire-door-drive ELEKTROMATEN

FS 25.20-30,00

Part no. 1000539200002

We undertake to provide the supervisory
authorities with specific documentation relating to
partly completed machinery upon justified
request.

This product must only be put into operation
when it has been determined that the complete
machine/system in which it has been installed
complies with the provisions of the above-
mentioned directives.

The signatory is the authorised representative for
compiling technical documents.

Düsseldorf, 17/11/2020

Stephan Kleine
Managing Director

Signature

The following requirements from Appendix I of
the Machinery Directive 2006/42/EC are met:
1.1.2, 1.1.3, 1.1.5, 1.2.2, 1.2.3, 1.2.6, 1.3.2,
1.3.3, 1.3.9, 1.5.1, 1.5.2, 1.5.4, 1.5.6, 1.5.7,
1.5.8, 1.5.9, 1.5.10, 1.5.11, 1.5.13, 1.6.1, 1.6.2,
1.6.4, 1.7.2, 1.7.3, 1.7.4.3.

Applied standards:

EN 60335-2-103:2015

Household and similar electrical appliances -
Safety - Part 2-103: Particular requirements for
drives for gates, doors and windows

EN 61000-6-2:2005

Electromagnetic compatibility (EMC) - Part 6-2:
Generic standards - Immunity for industrial
environments

EN 61000-6-3:2007

Electromagnetic compatibility (EMC) - Part 6-3:
Generic standards - Emission standard for
residential, commercial and light-industrial
environments

EN 16034:2014-12

Pedestrian doorsets, industrial, commercial,
garage doors and openable windows - Product
standard, performance characteristics - Fire
resistance and/or smoke control characteristics

EN 14637:2008-01

Building hardware - Electrically controlled hold-
open systems for fire/smoke door assemblies -
Requirements, test methods, application and
maintenance